

A WIDE RANGE TO MEET YOUR NEEDS

- **A range of round, square or rectangular vats** that will fit to your bowls and your work conditions.
- 10, 12, 16, 20, 24, 40, 48 or 80 **divisions** ? Single or dual cut-off ? **A wide range of potential uses and even more with our tailor-made subdivision grids.**
- Large capacity vats for more productivity...**You will product 1600 baguettes per hour with 40 divisions.**
... in a small space.



HIGH EFFICIENT TO MEET YOUR REQUIREMENTS

- Beveled blades to make **clean cuts of the dough.**
- Anti-adhesive coating of the cover (optional), plastic-coated hawks and a high quality vat with a good coating **avoid sticking and flour sprinkling.**
- **Better dough spreading** and air evacuation with steam vents (slits through which air escapes) all around the cover. When the cover is removed, deposits of dough fall into the vat and vents keep clean.
- Easy and quick sweeping of the rim of the vat.



HIGH EFFICIENT to meet your requirements
EASY HANDLING to work in good conditions
EASY CLEANING for best function and hygiene
Panirecord equipment is BUILT TO LAST
A TAILOR-MADE DIVIDER with custom fitting options

EASY HANDLING TO WORK IN GOOD CONDITIONS

- Dough pressing and dividing process, cutters lifting and lowering are activated by **a single control lever**.
- **The worktop is height fitted for better handling of bowls.** As the divider is not very deep, the lid handle in open position is easily accessible and **the space of work is more comfortable**.
- For **a quiet environment**, the hydraulic power unit only works when the control lever is activated.
- A **flour anti-spatter kit** is provided (*optional*) and enables the recovery of the clean flour in bilateral boxes.

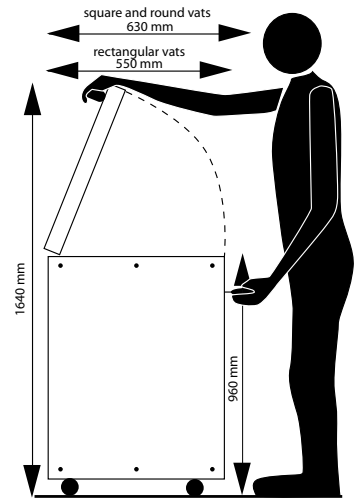

EASY CLEANING

- **To respect hygiene purposes**, vats and covers are in aluminium, hawks are in plastic and cutters in stainless steel.
- **Cutters are automatically released** for an easy cleaning.
- **Easy access inside the divider** allows problem-free cleaning. The base plate is covered with an anti-adhesive plastic coating for an easy cleaning.
- **A holed support enables to clean the flour on the floor**, thanks to vacuum clean after having moved the device mounted on castors.

PANIRECORD EQUIPMENT IS BUILT TO LAST

- Vat and cover are in aluminium alloy, cutters in stainless steel. The hydraulic power unit is oversized and dependent on the activation of the control lever for durability and reduced power consumption.
 - The system provides salt corrosion resistance : oven-baked paint of the frame and the hydraulic jack support, plastic safety protection of the base plate, anticorrosive treatment.
- A proven concept for maximum reliability, with no electronics.**



A TAILOR-MADE DIVIDER WITH CUSTOM FITTING OPTIONS

- A **flour anti-spatter kit** to protect your health.
- The **anti-adhesive cover** prevents the dough from sticking and reduce flour sprinkling.
- A **handy flour bin** (*photo to the left*).
- **Pressure adjustment** for all types of dough.
- **Divisions grids adaptable** for dividing dough into a variety of sizes (*photo above*).



THE TRADIRECORD DIVIDER-MOULDER

ANOTHER WAY TO MAKE BREAD

THE MULTI PURPOSE MACHINE PAR EXCELLENCE

- **A rectangular divider** to shape dough pieces into bread rolls or French baguettes after resting.
- **A moulder suitable for traditional breads**, with various flavour and appearance thanks to interchangeable grids, ready to be baked.
- **A fat press** to spread butter or pastry for confectioneries.



*Folding grid mounted on dampers
for a better bread moulding
(registered patent)*



STANDARD FEATURES :

- Folding grid support,
- Non adhesive cover,
- Pressure adjustment,
- Grid 10 baguettes,
- Grid 7 bread pieces,
- Transfer tray for dough pieces ready to bake,
- Flour bin,
- Grid support.

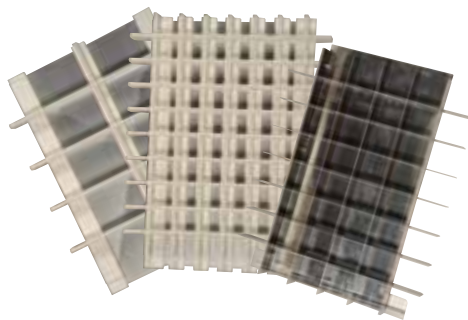

Plastic or stainless steel blade grids? It depends on the desired appearance :



A plastic blade pinches and joins the edges as a baker would do it.

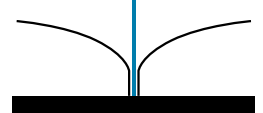

A stainless steel blade cuts, slices the dough, scored on one side.



TECHNICAL SHEET

VAT	DIMENSIONS CAPACITY	MODELS	DIVISIONS	TRADIRECORD	DIVISIONS DIMENSIONS in mm	WEIGHT OF DOUGH PIECES	
						mini	maxi
square 	48 x 48 x 13 cm 30 liters 5 to 20 kg	PC10	10	NO	238 x 94	500 g	2 kg
		PC12	12		158 x 118	400 g	1,6 kg
		PC16	16		118 x 118	300 g	1,25 kg
		PC20	20		118 x 94	250 g	1 kg
		PC24	24		118 x 78	200 g	800 g
		PC12/24	12/24		158/78 x 118	200 g	1,6 kg
		PC24/48	24/48		118/57 x 78	100 g	800 g
		TASSEUSE					
rectangular 	48 x 40 x 13 cm 25 liters 4 to 16 kg	PRE20	20	YES	118 x 78	200 g	800 g
		PRE40	40		78 x 57	100 g	400 g
		PRE80	80		57 x 37	50 g	200 g
		PRE20/40	20/40		118/57 x 78	100 g	800 g
		TASSEUSE					
round 	Ø 49,5 x 13 cm 30 liters	PRO20	20	NO		250 g	1 kg

OPTIONS AND ACCESSORIES :

- Anti-adhesive cover
- A flour anti-spatter kit
- Pressure adjustment
- Flour bin
- Aluminium or plastic transfer tray with or without silicone sheet
- Stainless housing
- Plastic dough bowl 390 x 540 x 80 mm «Special Tradirecord»
- Trolleys available for 15 trays of 100 mm (H 1,73 m)
- Trolleys available for 20 trays in aluminium of 75 mm (H 1,73 m)

FOLDING GRIDS*	in plastic or stainless steel for Tradirecord model	DIVISION GRIDS *	for dividers PRE / PC
divisions	dimensions in mm	divisions	dimensions in mm
6	400 x 78	20	118 x 78/94
7	400 x 67	24	118 x - /78
8	400 x 58	40	57 x 78/94
9	400 x 52	48	78 x - /57
10	400 x 46	72	57 x 42/53
12	400 x 38	80	57 x 37/46
10 = 2 x 5	199 x 94	96	57 x 32/38
16 = 2 x 8	199 x 58	* Here is a list of the most requested grids. For any further information, please contact us. Motor power : 1,5kW 230/400V 50/60 Hz 5.9/3.4A Sound level at 1 m : 83 dB. Meet EC standards	
20 = 2 x 10	199 x 46		
6 = 2 x 3	199 x 158		
12 = 3 x 4	132 x 119		
40	78 x 58		
50	78 x 46		
80	48 x 46		

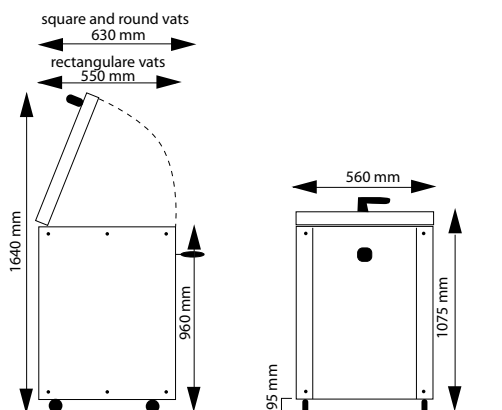

PANIRECORD - 6 Zone Industrielle - 77890 Beaumont du Gatinais - France
 SAS au capital de 37 000 € - RCS Melun
 Siret : 354 044 554 000 13 N° identification CEE : FR 673 540 44 554
 Tél : +33 (0)1 64 29 90 21 - Fax : +33 (0)1 64 29 95 96
 www.panirecord.fr - e-mail : info@panirecord.fr

All information and the photographs of this document are noncontractual and can be modified constantly without notice. Not to throw on the public highway - Graphic design **2iD COM**